

Smart control system for LEDs traffic-lights based on PLC

RAMÓN MARTÍNEZ-RODRÍGUEZ-OSORIO, MIGUEL CALVO-RAMÓN, MIGUEL Á.
FERNÁNDEZ-OTERO, LUIS CUELLAR NAVARRETE

Dpt. de Señales, Sistemas y Radiocomunicaciones. Universidad Politécnica de Madrid
ETSI de Telecomunicación. Ciudad Universitaria s/n. 28040 Madrid

SPAIN

ramon@gr.ssr.upm.es <http://www.gr.ssr.upm.es>

Abstract: - The scope of this paper is to present the initial steps in the implementation of a smart traffic light control system based on powerline communications (PLC) technology. The system operates with traffic lights implemented with LED technology, that has a number of advantages as compared to traditional incandescent lamps. The proposed system makes use of the transmission media to communicate different traffic light groups with a central regulator in order to exchange information about the status of the lighting elements. From the regulator, the status and operation of the traffic light group can be monitored and changed according to traffic conditions and time. The proposed system provides a reduction in the long term maintenance costs, and can be used to remotely control the operation of traffic lights.

Key-Words: - Communication system; FPGA; LED; traffic light; powerline communications.

1 Introduction

Since the beginning of traffic signalling as a tool for traffic control, traffic lights have worked by means of incandescent lights, with a power supply of 220 V, in conjunction with a crystal diffuser or tinted methacrylate with the appropriate colour (red, green or amber) and a front reflector.

A traffic light group is defined as a set of traffic lights which are controlled by the same regulator, which acts as a master or coordinator. The regulator operates under a intelligent system that allows for controlling the lights status depending on time, traffic conditions, etc.

In the last 70 years, several innovations on the original concept of traffic light control have been introduced. These innovations consist in the introduction of complex routines such as macro-and micro-regulation, redundancy to increment the security, more efficient and economical reflectors, etc. However, one aspect that remains the same in all the cases is the use of incandescent lights as the lighting element.

During the 80s, a new lighting technology was introduced: Light Emitting Diodes, most commonly known as LED. LEDs can be power supplied with a dc voltage and are able to emit light in a specified wavelength. LED technology is commonly used in displays, panel indicators, remote controls, television screens, etc.

LED technology has experienced a great evolution in the last few years, having a lower fabrication cost with the possibility of having LED with different illumination colour. LEDs are specially

constructed to release a large number of photons outward. Additionally, they are housed in a plastic bulb that concentrates the light in a particular direction.

The application of LEDs in traffic lights has several advantages with respect to incandescent bulbs:

- LEDs do not have a filament that burn out, so that they do not get especially hot in contrast to incandescent bulbs;
- LEDs last much longer than incandescent lamps, what means that the long term operation and maintenance costs are significantly lower than for incandescent bulbs;
- Light production process is significantly more efficient than in incandescent bulbs, where a huge portion of the available power supply is used to heat the filament and is not directly used in the production of light;
- A large number of applications can be implemented with LEDs as traffic lighting elements: modification of lighting condition depending on climatic conditions, change in the crossing time for pedestrians, failure detection, generation of alarms, etc.

Figure 1 shows a comparison between the emission spectrum of LEDs and incandescent bulb as red traffic lights [1]. The number of LEDs used in a traffic light depends on the manufacturer. In the figure, 680 LEDs are allocated in concentric circles. As it can be seen in the light spectrum for the red light, the LED produces a narrower band of

wavelengths concentrated around the red wavelength (657 nm), which means that the light and colour emitted by the traffic light will be much brighter. Moreover, the power supply level needed for the incandescent light is 7.3 dB higher in order to obtain the same intensity.

In order to implement the applications indicated, a certain level of intelligence is required in both the traffic light and the regulator. Therefore, a communication link must be established, so that a transceiver must be installed in both sites of the link (traditional traffic control system are unidirectional from regulator to traffic lights, without any response from the status of the traffic lights).

There are different transmission media than can be used. Physical layers based on radio technology are likely to receive the disturbances provided by impulsive noise from car engines, which is a significant interference contribution in different frequency bands. Wired technologies such as fiber, coaxial or copper lines are not available between traffic light and regulator, so that a significant deployment cost is required. Therefore, the use of power lines as transmission media is foreseen as the most appropriate technology as there is no need of deploying new infrastructure.

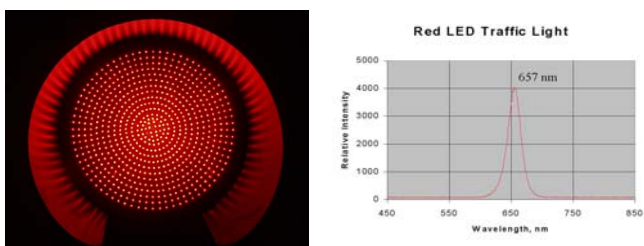

(a) Traffic light formed by 680 LEDs (25 W)

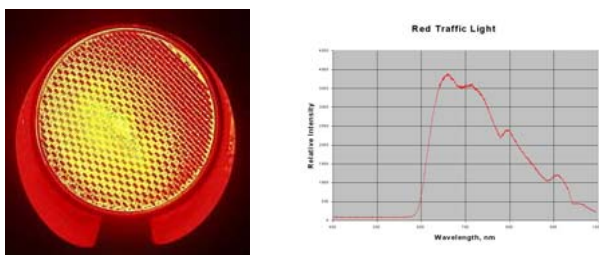

(b) Incandescent bulb (135 W)

Figure 1. Traffic light implemented with LED and incandescent bulb (Source: [2]).

The scope of this contribution is to present a PLC-based smart traffic light control, where the communication link is established using the power lines used to feed the traffic light groups.

The structure of the paper is as follows. Section 2 describes the architecture of the system. Section 3 details the specifications and requisites of the

communication systems, and section 4 shows the selected hardware platform and software tools used to implement the testbed.

2 System architecture

The architecture of the communications system must take into account the topology of the power lines that supply power to each traffic light. In typical situations, low voltage power lines are installed from the regulator to the traffic lights, resulting in a star topology.

According to the deployment of traffic light groups, the topology of the communication system from the regulator to the traffic lights follows a point-to-multipoint architecture. This means that a regulator controls several of traffic lights depending on each particular situation. In most of the cases, a regulator controls all the traffic lights used to manage the traffic in a street crossing, as it can be seen in Figure 2. Distances between the regulator and the traffic light groups typically vary in a range from 70 to 400 m.

In a traffic light control system, the required bit rate is low enough to be transmitted through power lines. As well, the conditions of the propagation channel are favourable to establish the link as typical conducted interference that appear in a PLC-based system are not found in traffic control scenario (dedicated low voltage lines to power supply the traffic lights are used). On the other hand, the star based topology reduces channel impairments such as impedance mismatching, echoes and multipath propagation.

There are different architectures to implement the control system. In present traffic control systems, the intelligence of the system is completely installed in the controller, so that the controller is in charge of switching lights, generate alarms, etc. This is carried out by means of a power interface boards composed of triacs and optocouplers between the traffic lights and the controller.

The architecture of the proposed system is based on the installation of a PLC modem in both the traffic light group and in the controller. Apart from the communications tasks, the PLC modem installed in the traffic light takes charge of the light operation. This new concept means that the information flow between traffic light and regulator is significantly reduced, as the controller is no longer responsible for transmitting all the control signals to the traffic lights. On the other hand, traffic light groups will inform the controller of the current status, with special emphasis of alarm situations (fused light, power supply failure, etc.).

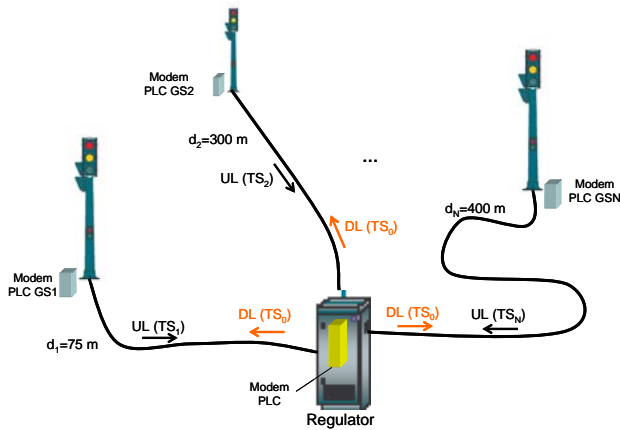

Figure 2. Point-to-multipoint topology of the communication system.

3 System specifications

The most important specification of the communication system is the refresh period. This time interval indicates which is the maximum time period required to evaluate the status of a traffic light. In the particular case of the proposed traffic light control system, a refresh period of 100 ms has been specified.

The communication is bidirectional. The messages that can be transferred in downlink and uplink directions are:

- Downlink (from the controller to the traffic light): in this case, the controller orders the traffic light to change the its status in case it is needed (e.g., if one traffic light is not working in a street crossing, then the rest of groups of the crossing must be switched to the alarm state with the amber light blinking);
- Uplink (from the traffic light modem to the controller): the traffic light group sends information about the current status of the lights (normal operation, fusing, etc.).

Normally, one traffic controller takes charge of more than one traffic group. In our application, each traffic controller is able to control up to 8 traffic light groups.

The transmission is organized in time frames of 100 ms. Each frame is divided in 9 time slots: the first one is for the downlink transmission, where the information for all the traffic lights groups is sent simultaneously using CDMA. In the uplink, each traffic light group transmits in a different time slot. The reason for using CDMA is the electromagnetic environment that appears in a traffic control scenario, where there is a number of impulsive noise sources coming from motor ignition [3], [4].

The configuration of each time slot has been adapted from the Echonet specifications [5] for the

powerline transmission media. Each time slot is divided in three parts: preamble, synchronization and data. Figure 3 shows the structure of a frame in the downlink. Guard intervals are inserted between time slots to account for the propagation delays between different traffic lights paths. Typical propagation delays that appear in a real scenario are in the range of 0.23 to 1.66 μ s.

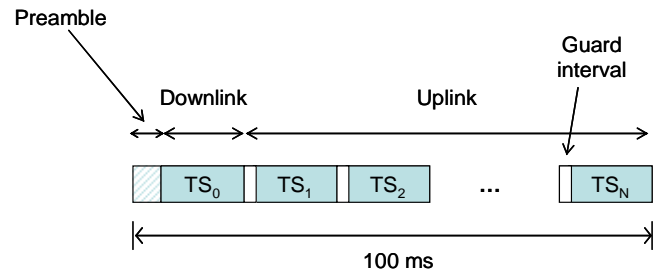

Figure 3. Frame structure.

The transmission scheme in the downlink is shown in Figure 4. The preamble is a period of a Gold code with good autocorrelation properties [6]. As well, Gold codes can be implemented with a minimum number of resources in the selected hardware platform [7]. The preamble interval is used for the detection of a transmission. The synchronization and data fields are concatenated and then spread by a family of 32-chip Walsh codes, similar to the ones used in UMTS. Finally, the contributions of all the traffic groups is summed and scrambled by the previous Gold code.

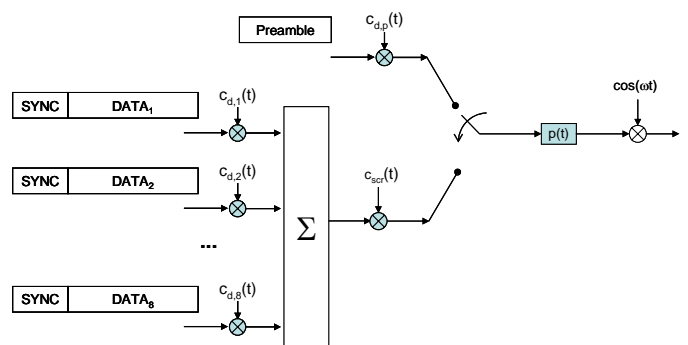

Figure 4. Downlink transmission scheme.

Regarding the transmit information, the number of status is 31 (which combination of lights is active, alarm status, etc.), so that a data field of 5 bits is enough to provide the complete information on the traffic light operation. The dimensioning of the time slot has been defined according to the following parameters:

- Preamble: 8 bits (empty)
- Synchronization field: 16 bits
- Data field: 16 bits

The message has a total length of 40 bits. In order to perform the slot detection, a common pilot channel is summed up time-aligned with the slot. The pilot channel is formed by five periods of the Gold code used for the scrambling of users. The preamble period is empty, so that only one period of the Gold code is transmitted without overlapping with other. The filtered signal of the downlink is shown in Figure 5.

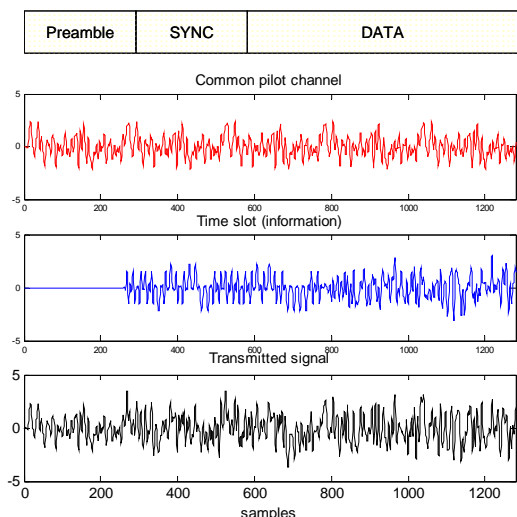

Figure 5. Baseband filtered signal corresponding to a time slot in the downlink.

The slot detection is achieved after the correlation between the received signal with a local copy of the Gold code. Due to its good autocorrelation properties, a maximum of the correlation appears when a slot is detected. The maximum value for the correlation depends on the channel conditions. Figure 6 shows the correlation result for a SNR=5 dB. As it can be seen, five correlation peaks appear, corresponding to the five periods of the Gold code within a slot. The maximum appears in the first period (preamble) as no other source apart from thermal noise interfere with the pilot signal.

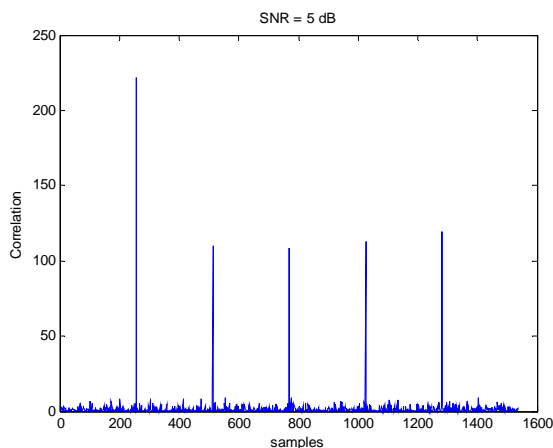

Figure 6. Correlation result in one slot.

4 Hardware and software platforms

The block diagram of the prototype for the modem in the traffic light is shown in Figure 7. It is formed by an FPGA (Field Programmable Gate Array) connected to an interface board with the lighting element, a digital-to-analog and analog-to-digital converter. Then, the signal is injected in the power line using an inductive coupling unit. In the regulator, the block diagram is similar except for the interface with the light elements (as an application, the modem in the controller can be connected with a PC through the RS232 or USB interfaces).

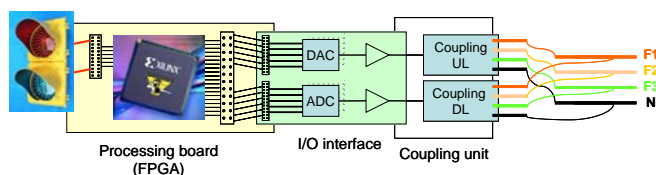

Figure 7. Block diagram of the prototype.

The FPGA board selected for this prototype is a Spartan 3-E evaluation board [8]. The selection of an FPGA as the device for controlling the system is motivated for its flexibility and because the number of I/O ports (pins) is large enough to connect several lighting element. The clock of the FPGA is 100 MHz [9].

The available bit rate depends on the spreading factor, the time slot duration and the FPGA clock. With 40 bits per slot, a spreading factor of 32 and a guard interval of 6.8 ms, the maximum bit rate is 12.5 kbit/s. However, the bit rate can be halved in situation where the guard interval can be reduced up to 3.4 ms. Therefore, the chip rate can be easily obtained dividing the FPGA clock rate by 250 or 500.

Using an oversampling of 4 for the root-raised cosine filtering, the base band sample rate is 800 or 1600 ksamples/s. With this sample rate and taking into account the FPGA clock, we can think of a sigma-delta modulation to implement the digital-to-analog conversion. Thanks to the noise shaping produced by the oversampling factor and low-pass filtering, the number of required resolution bits is reduced in comparison with a uniform quantization. Implementing one-bit $\Sigma\Delta$ modulation included in the FPGA, the number of hardware devices of the prototype is reduced (note that for the digital-to-analog conversion, a fast comparator is required [10]). The selected oversampling rate must be much higher than twice the maximum signal frequency. The carrier is centered in the 400 KHz.

Figure 8 shows the connection of the interface board with the FPGA module in the traffic light position. The interface provides an indication of the status of LEDs, measuring the voltage reduction due

to the fact that the LED light is fused. In the initial prototype, the PLC modem installed in the traffic light site is prepared for the monitoring of 8 light elements.

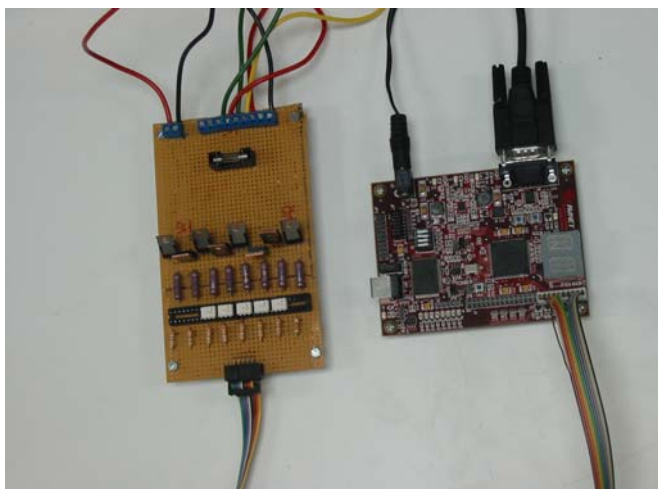

Figure 8. Interface board connected to the modem in the traffic light group.

Figure 9 shows the implemented test scenario for the traffic light control. In the first version of the prototype, we have limited to one the number of traffic light groups that can be controlled by one regulator. As it can be seen the number of lighting elements whose status we have to control is 7 (two for the pedestrian lights, 3+2 for the car lights).



Figure 9. Testbed for the smart traffic light control based on PLC.

Different software design tools have been used. First, Matlab® has been used for simulation and design of modulation, spreading and other communications parameters. The tool used for FPGA design has been ISE Foundation®, so that the code

has been constructed in VHDL from scratch. ModelSim® has been selected for hardware emulation to verify the functional and timing models of the design. The Link for ModelSim add-in included in Matlab® has been also used for the verification of the signals generated by the FPGA.

Acknowledgment

Authors wish to thank SICE, S.A., for the financial support of this research work.

References:

- [1] Ramón Martínez, Miguel Calvo, F.J. García-Madrid, Luis Cuéllar, "Specifications for the Smart Traffic Light Control System using LED technology," *Report No. UPM/GR/27/2005*, v1.0, Dec. 2005.
- [2] Interdisciplinary Education Group, University of Wisconsin, Traffic Spectra [online]. Available: http://mrsec.wisc.edu/Edetc/LED/traffic_light/spectra.htm.
- [3] D. Middleton, "Man-made noise in urban environments and transportation systems: Models and measurements," *IEEE Trans. Veh. Technol.*, vol. VT-22, no. 4, pp. 148-157, Nov. 1973.
- [4] R. A. Shepherd, "Measurements of amplitude probability distributions and power of automobile ignition noise at HF," *IEEE Trans. Veh. Technol.*, vol. VT-23, no. 3, pp. 72-83, Aug. 1974.
- [5] Echonet Specifications, *Part 3: Transmission Media and Lower-layer Communication Software Specification* [online]. Available: www.echonet.gr.jp/english.
- [6] J. S. Lee, L. E. Miller, *CDMA Systems Engineering Handbook*, Artech House, 1998.
- [7] Maria George, Mujtaba Hamid, and Andy Miller, "Gold Code Generators in Virtex Devices," Xilinx Application Note xapp217, v1.1, January 10, 2001.
- [8] Xilinx® Spartan™-3E Evaluation Kit, Avnet Electronics Marketing, <http://www.avnet.com>.
- [9] Xilinx Spartan™-3E FPGAs, Reference Documentation [online]. Available: <http://www.xilinx.com/spartan3e>.
- [10] "Demystifying Sigma-Delta ADCs," Maxim Application Note AN1870, January 2003.